



Level Switch Type

NRS 1-42



CANopen

EN
English

Original Installation Instructions
810373-04

Contents

Page

Important Notes

Usage for the intended purpose	7
Safety note	7
Warning	7

Explanatory Notes

Scope of supply	8
System description	8
Function	8
Technical data	9

Installation

NRS 1-42	10
Example of installation	27

Wiring

Wiring diagram	3, 4, 10, 11
----------------------	--------------

Basic Adjustment

CAN bus	12
Node ID	12
Factory setting	12
Adjust sensitivity	13

Operation

On-off control	14
Switchpoint 1	14
Switchpoint 2	14
Switchpoint 3	14
Switchpoint 4	14
Alarm	15
High-level (MAX) alarm	15
Low-level (MIN) alarm	15
Relay test high level / low level	15

System Malfunctions

Systematic analysis of malfunctions 1 – 3	16–20
---	-------

Malfunctions

Fault-finding list for troubleshooting	21, 22
--	--------

Annex

Factory set default node IDs	23
Assigning/changing node IDs	23, 24
Note on the Declaration of Conformity / Declaration by the Manufacturer CE	25

Wiring Diagram

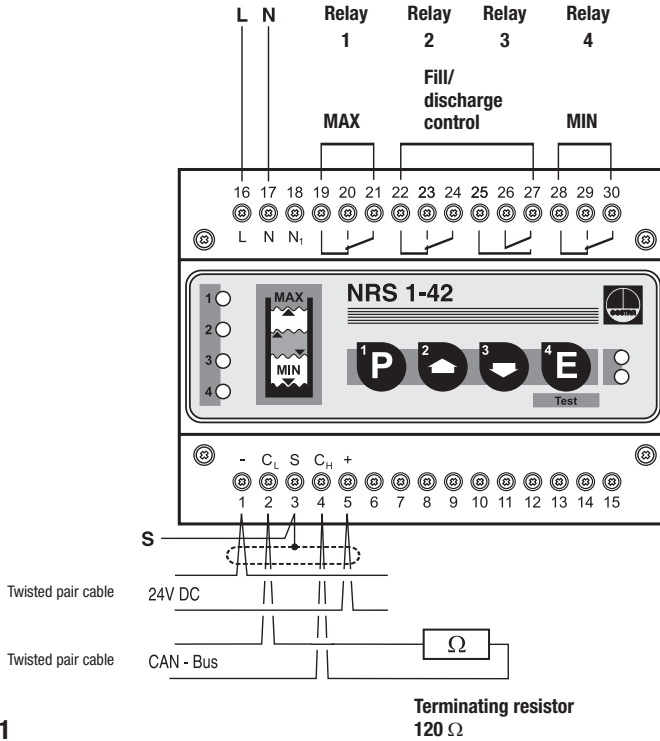
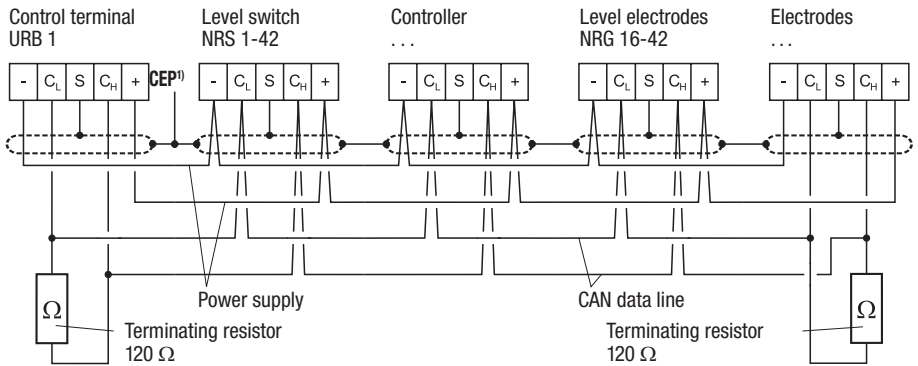

Fig. 1



¹⁾ CEP = central earthing point

Fig. 2

Wiring Diagram

Discharge control – Pump OFF at low level

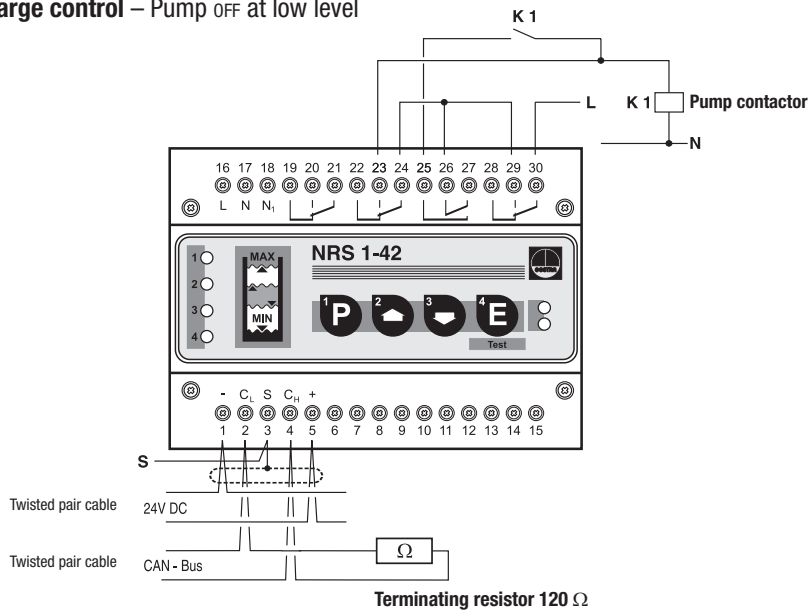

Fig. 3

Fill control – Pump OFF at high level

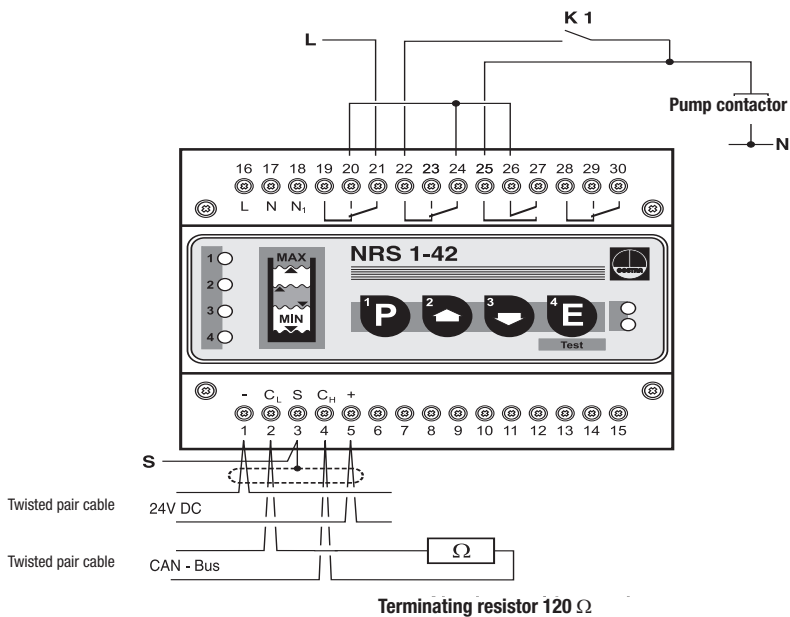

Fig. 4

Parts Drawing

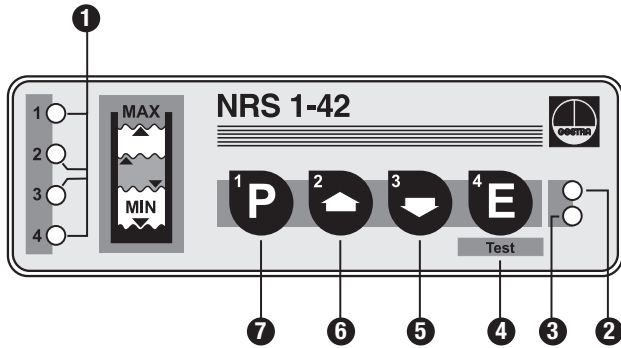

Fig. 5

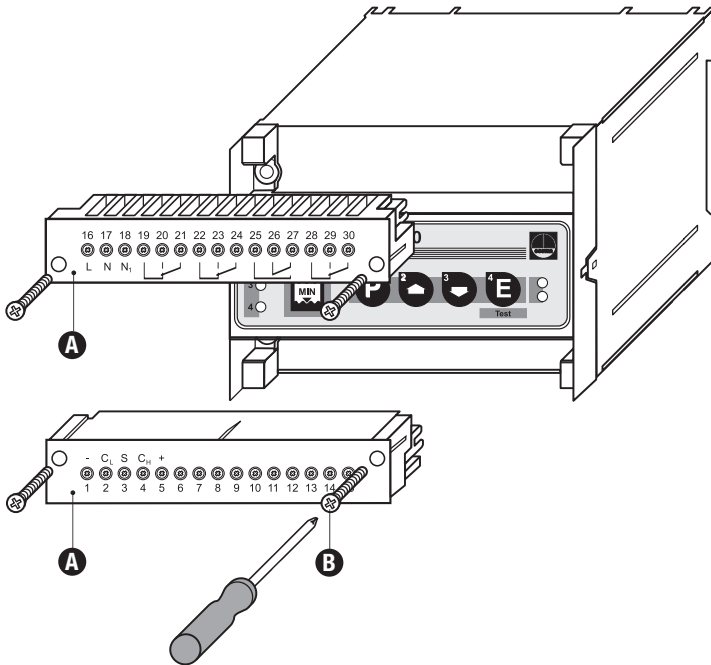

Fig. 6

Key

1 Indicator LEDs

LED 1 – switchpoint 1

LED 2 – switchpoint 2

LED 3 – switchpoint 3

LED 4 – switchpoint 4

Discharge control

High-level alarm

Pump ON

PUMP OFF

Low-level alarm

Fill control

High-level alarm

Pump OFF

Pump ON

Low-level alarm

2 LED “Bus status”

3 LED “Power”

4 Enter button / test mode

5 Decrease button

6 Increase button

7 Program button

8 Code switch, 10 poles

A Terminal strip

B Screws for terminal strip

Important Notes

Usage for the intended purpose

Use level switch NRS 1-42 in conjunction with level electrode NRG 16-42 only for level signalling in liquid and electrically conductive fluids.

Safety note

The equipment may only be installed, electrically connected and commissioned by suitable persons with the relevant instruction/training.

Qualified staff are those persons who – through adequate training in electrical engineering, the use and application of safety equipment in accordance with regulations concerning electrical safety systems, and first aid & accident prevention – have achieved a recognised level of competence appropriate to the installation and commissioning of this device.



Warning

The terminal strips of the NRS 1-42 are live during operation! There is a risk of serious injury due to electric shock!

Always cut off the power supply to the equipment before installing, removing or connecting terminal strips and/or the cover.

Explanatory Notes

Scope of supply

NRS 1-42

1 Level switch type NRS 1-42 (plug-in unit in plastic case with terminals)

1 Terminating resistor 120 Ω

1 Installation manual

System description

Use level switch type NRS 1-42 together with level electrode type NRG 16-42 for level monitoring. The level switch has the following functions:

- Four levels with one switchpoint each.
- High-level alarm, low-level alarm, pump ON, pump OFF with one switchpoint each.

The level data are transferred from the electrode NRG 16-42 to the level switch via a CAN bus.

Function

At regular intervals the level electrode NRG 16-42 sends a data telegram to the level switch NRS 1-42. The data transfer is effected by means of a CAN bus according to DIN ISO 11898. The transferred measuring data are then evaluated and assigned to the manually adjusted switchpoints. To guarantee the correct functioning and safety of the system the data transmitting cycle of the level switch is constantly monitored by the level switch. When the CAN bus line is interrupted the level switch sends a visual signal to indicate a malfunction and the relays 1 and 4 will be instantaneously de-energized (fail-safe position).

Additional functions, such as (de-)energizing delay times of the output relays (1 to 25 seconds), can be adjusted with the control terminal and display unit URB 1.

Technical data

Type approval n°

TÜV · WR xx-399

Input / Output

Interface for CAN bus to DIN ISO 11898 CANopen

Output – voltage supply for electrode

Power supply 24 V DC, short-circuit protected

4 volt-free relay contacts.

Max. contact rating with switching voltages of 24V AC, 115V AC and 230V AC: 4A resistive, 0.75A inductive at $\cos \varphi 0.5$

Max. contact rating with a switching voltage of 24V DC: 4A.

Contact material: silver, hard-gold plated

Interference suppression

Provide contactor with an external RC combination (100 Ω / 47 nF)

Relay de-energizing delay

Output "MIN", "MAX" 3 s

Indicators and adjustors

4 pushbuttons for parameterisation/"TEST"

1 red LED for switchpoint "HIGH LEVEL" (MAX)

1 red LED for switchpoint "LOW LEVEL" (MIN)

2 green LEDs for switchpoints "pump ON" and "pump OFF"

1 green LED "POWER"

1 red LED "BUS STATUS"

1 ten-pole code switch, 7 poles for node ID and 3 poles for baud rate settings

Sensitivity

Range 1: $\geq 10 \mu\text{S/cm}$

Range 2: $\geq 0.5 \mu\text{S/cm}$

Supply voltage

230 V $\pm 10\%$, 50/60 Hz

115 V $\pm 10\%$, 50/60 Hz (option)

Power consumption

10 VA

Protection

Case: IP 40 to DIN ISO 60529

Terminal strip: IP 20 to DIN ISO 60529

Admissible ambient temperature

0 °C to 55 °C

Enclosure material

Front panel: polycarbonate, grey

Case: polycarbonate, black

Weight

Approx. 0.8 kg

Installation

NRS 1-42

Installation on mounting rail

1. Clip level switch onto mounting rail 35 x 15 mm (DIN EN 50022).
2. Align level switch, **Fig. 11, Fig. 12**

Tool

- Screwdriver (5.5/100)

Wiring

Note that screened multi-core twisted-pair control cable is required, e. g. UNITRONIC® BUS CAN 2 x 2 x ...² or RE-2YCYV-fl 2 x 2 x ...².

The baud rate (data transfer rate) dictates the cable length between the bus nodes and the total power consumption of the measuring sensors dictates the conductor size.

S 8	S 9	S 10	Baud rate	Cable length	Number of pairs and conductor size [mm ²]
OFF	ON	OFF	250 kBit/s	125 m	2 x 2 x 0.34
Factory setting					
ON	ON	OFF	125 kBit/s	250 m	2 x 2 x 0.5
OFF	OFF	ON	100 kBit/s	335 m	2 x 2 x 0.75
ON	OFF	ON	50 kBit/s	500 m	on request, dependent on bus configuration
OFF	ON	ON	20 kBit/s	1000 m	
ON	ON	ON	10 kBit/s	1000 m	

The baud rate is set via a code switch. Reduce baud rate if cable is longer than specified in the table. Make sure that all bus nodes have the same settings.

To protect the switching contacts fuse circuit with 2.5 A (anti-surge fuse) or according to TRD regulations (1.0 A for 72 hrs operation).

If a cable length of more than 125 m (max. 1000 m) is desired, make sure to modify the baud rate accordingly. Refer to pages 23 and 24 for more details.

Wiring diagram

See wiring diagrams on page 3 and 4.



Attention

- Wire equipment in series. Star-type wiring is not permitted.
- Interlink screens of control cables such that electrical continuity is ensured and connect them **once** to the central earthing point (CEP).
- To protect the switching contacts fuse circuit with T 2.5 A or according to TRD regulations.
- If more than one system component is connected to a CAN bus network provide the first and last equipment with a terminating resistor of 120 Ω. **Fig. 2**
- The CAN bus network must **not** be interrupted while operating.

Any interruption will result in HIGH/LOW level alarm!

If the level controller must be replaced, remove terminal strip **A** **Fig. 6**.

Before removing the CAN-bus line from the terminal strip disconnect all relevant system components.



Note

- Connect screen only to terminal 3, ensuring electrical continuity and connect it **once** to the central earthing point (CEP).
- The loop resistance must be under 10 Ω.
- The rated voltage is stated on the name plate.
- When switching off inductive loads, voltage spikes are produced that may impair the operation of control and measuring systems. Inductive loads should therefore be provided with commercial arc suppressor RC combinations, e. g. 0.1 μF/100 Ω.
- In spite of correct wiring H. F. interference caused by the installation may lead to system breakdowns and malfunction messages. If necessary refer to the **“Fault finding list for troubleshooting”** on page 21.

Tool

- Screwdriver for slotted screws, size 2.5, completely insulated according to VDE 0680.

Basic Adjustments

CAN Bus

All level and conductivity controllers and associated electrodes are interconnected by means of a CAN bus using the CANopen protocol. Every item of equipment features an electronic address (node ID). The four-core bus cable serves as power supply and data highway for high-speed data exchange. The CAN address (node ID) can be set between **1** and **123**.

The NRS 1-42 is configured at our works and ready for service with other GESTRA system components without having to set the node ID.

If several systems of the same kind are to communicate in one CAN bus network, be sure to assign one node ID for each individual system component. Refer to pages 23 and 24 for more details.

Node-ID

Reserved	NRS 1-42	NRG 16-42	
X - 1	1	X + 1	
	20	21	Factory setting

Reserved area

Factory setting

The level switch features the following factory set default values:

- Baud rate: **250 kb/s**
- Sensitivity: **10 µS/cm**
- Node ID: **020**
- Relay with energizing delay switchpoint 1: **0s**
- Relay with energizing delay switchpoint 4: **0s**
- Relay with de-energizing delay switchpoint 1: **3s**
- Relay with de-energizing delay switchpoint 4: **3s**

Basic Adjustments – continued –

Adjust sensitivity 0.5 $\mu\text{S}/\text{cm}$

Press button **P** briefly.

Sensitivity range 1 (10 $\mu\text{S}/\text{cm}$, factory-set default value) is activated.

Use button **2** and **3** to switch between sensitivity range 10 $\mu\text{S}/\text{cm}$ and 0.5 $\mu\text{S}/\text{cm}$.

LED illuminated

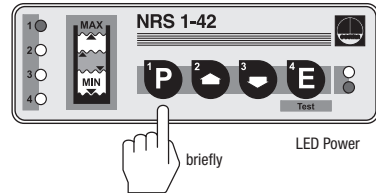

Press button **2** briefly.

Sensitivity 0.5 $\mu\text{S}/\text{cm}$ is selected.

LED illuminated

LEDs flash slowly

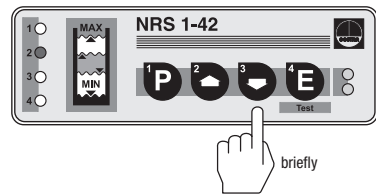

Press button **P** briefly.

Note:

When in program mode in the event of a system malfunction the LED “Bus status” and/or the LED “Power” flash **rapidly**. Quit program mode and analyse system malfunction (see pages 16 – 18).

LED flashes

LEDs flash slowly

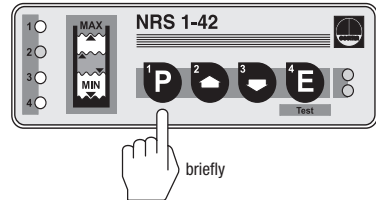

Press button **E** twice briefly.

Sensitivity range 0.5 $\mu\text{S}/\text{cm}$ is saved.

The four indicator LEDs signal the present operating mode.

LEDs indicate present operating mode

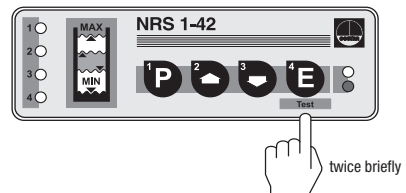

Operation

ON-OFF Control

The setpoint range of the liquid level is reached when electrode tips 3 and 4 are submerged and electrode tips 1 and 2 are exposed.

Note: All LEDs go out once the setpoint is reached.

LEDs indicate present operating mode

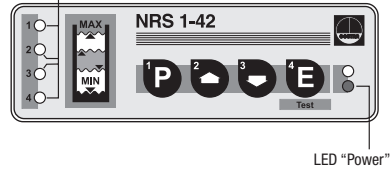

Switchpoint 1

Switchpoint 1 reached

- Time delay activated, LED 1 flashing
- Time delay elapsed, LED 1 permanently illuminated, relay 1 de-energized

Level below switchpoint 1

- LED 1 goes out, relay 1 energized

Switchpoint 2

Switchpoint 2 reached

- Time delay activated, LED 2 flashing
- Time delay elapsed, LED 2 permanently illuminated, relay 2 energized

Level below switchpoint 2

- LED 2 goes out, relay 2 de-energized

Switchpoint 3

Level below switchpoint 3

- Time delay activated, LED 3 flashing
- Time delay elapsed, LED 3 permanently illuminated, relay 3 energized

Switchpoint 3 reached

- LED 3 goes out, relay 3 de-energized

Switchpoint 4

Level below switchpoint 4

- Time delay activated, LED 4 flashing
- Time delay elapsed, LED 4 permanently illuminated, relay 4 de-energized

Switchpoint 4 reached

- LED 4 goes out, relay 4 energized

Operation – continued –

Alarm

There are two alarm conditions:

- **High-level (MAX) alarm**
- **Low-level (MIN) alarm**

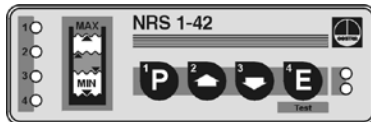

High-Level (MAX) Alarm

LED 1 flashes rapidly.

LED 1 remains permanently illuminated after the de-energizing delay.



Low-Level (MIN) Alarm

LED 4 flashes rapidly.

LED 4 remains permanently illuminated after the de-energizing delay.



Relay Test MIN/MAX

Press button **E** briefly.

The test mode is activated for 5 seconds.

LEDs illuminated

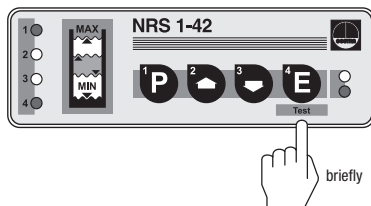

Hold down button **E**.

LED 4 goes out.

A low-level (MIN) alarm is simulated for switchpoint 4.

Indicator LED 4 goes out

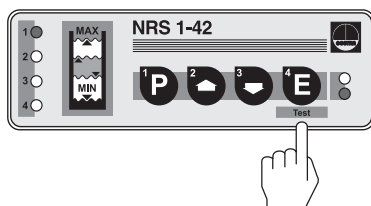

Hold down button **P**.

LED 1 goes out.

A high-level (MAX) alarm is simulated for switchpoint 1.

Indicator LED 1 goes out

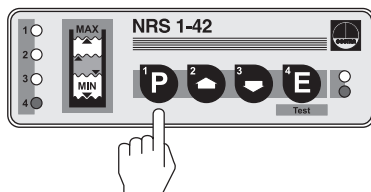

System Malfunctions

Faulty installation and/or configuration of CAN bus components, excessive temperatures in the devices, defective electronic component parts or electromagnetic interferences of the supply system can result in system malfunctions.

There are four system malfunctions that might occur in the level switch and the level electrode:

- Max. admissible temperature in electrode terminal box exceeded
- No or faulty communication between controller and electrode
- Fault in CAN bus
- Failure of 24 V power supply unit built in level switch NRS 1-42



Danger

The terminal strip of the NRS 1-42 is live during operation.

This presents the danger of electric shock.

Cut off power supply before mounting or removing the equipment.

Systematic Malfunction Analysis

The sources of malfunctions occurring in CAN bus systems operating with several bus-based stations must be analysed systematically since faulty components or incorrect settings can give rise to negative interactions with intact bus devices in the CAN bus system. These unwanted interactions can cause error messages in fully functional bus devices, which will make fault detection even more difficult.

We recommend the following systematic fault finding procedure:

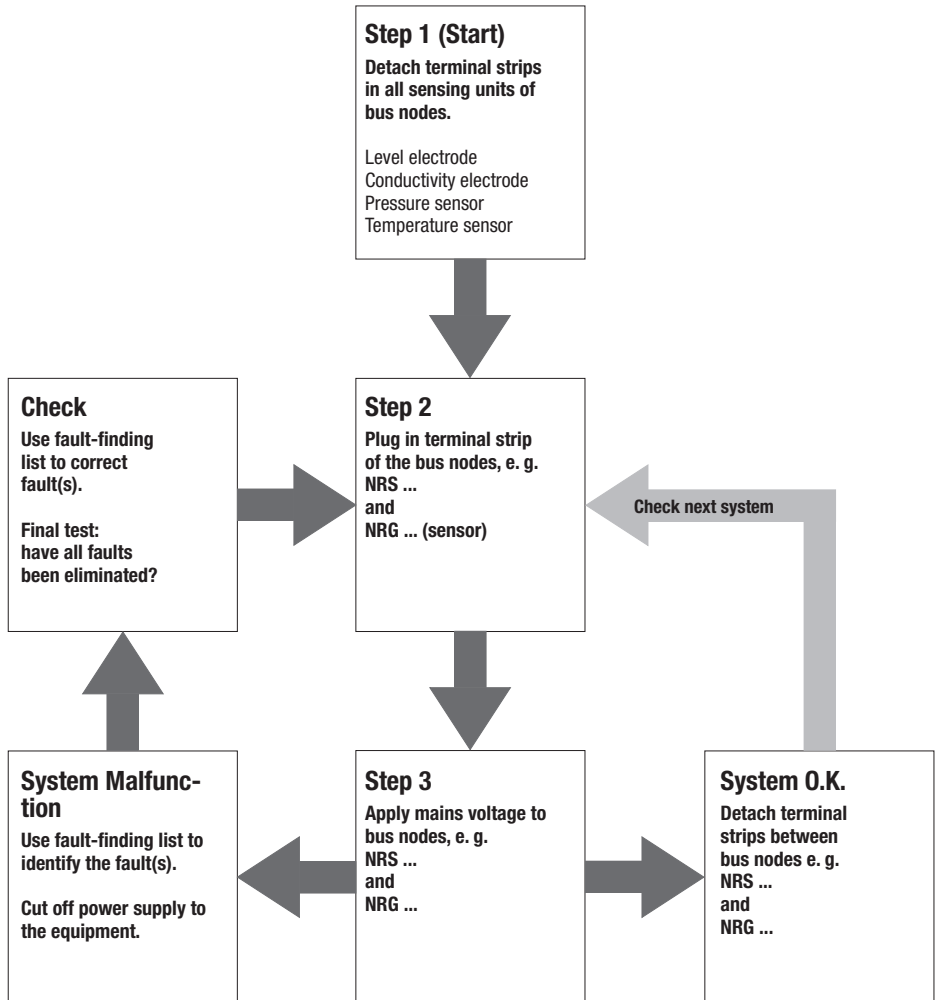

System Malfunctions – continued –



Danger

The terminal strip of the NRS 1-42 is live during operation. This presents the danger of electric shock. Cut off power supply before mounting or removing the equipment.

System Malfunction 1

The four indicator LEDs flash slowly.

MAX/MIN alarm

LEDs flash slowly

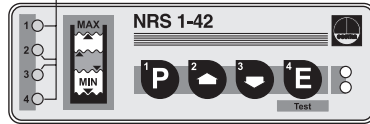

Fault: The max. admissible temperature in the electrode terminal box is exceeded.

Remedy: Insulate electrode flange to protect the equipment against heat radiation.

As soon as the temperature drops below the max. admissible limit the equipment automatically returns to normal operation.

System Malfunction 2

The four LEDs flash rapidly.

MAX/MIN alarm

LEDs flash rapidly

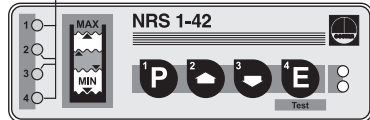

Fault: The CAN bus line between the nodes is interrupted.

Remedy: Check wiring and terminals. Restart system.

Fault: Incorrect node ID settings.

Remedy: Set correct node ID(s), referring to sections “Basic Adjustment” and “Annex”. Disconnect the system from its power supply. After 5 sec. connect power and restart system.

System Malfunctions – continued –

System Malfunction 3

The four indicator LEDs flash slowly.

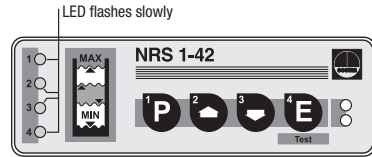

Fault: The plausibility test shows that the low level electrode ends above high level.

Remedy: Check electrode tips and, if necessary, correct the assignment of the connectors on the preamplifier board of the electrode.

System Malfunction 4

LED “Bus status” flashes slowly.

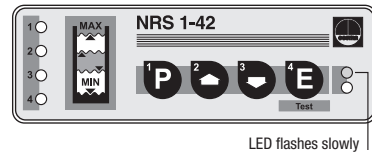

Fault: Malfunction in CAN bus.

Remedy: Restart system.

LED “Bus status” flashes slowly
MAX/MIN alarm

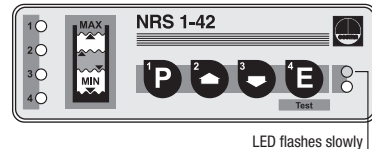

Fault: Data transfer in CAN bus interrupted.

Remedy: The bus cables have to be correctly connected according to the wiring diagram (observe polarity!). Make sure that all **end-of-line nodes** are provided with 120 Ω terminating resistors. Disconnect the system from its power supply. After 5 sec. connect power and restart system.

Fault: The baud rate of one or more nodes is not set correctly.

Remedy: Check baud rate settings of all bus nodes. The baud rates **must be identical**. Refer to section “Annex” for more details. Disconnect the system from its power supply. After 5 sec. connect power and restart system.

Fault: The overall length of the bus cable does not correspond to the selected baud rate.

Remedy: Change baud rate settings of all nodes according to the ratings indicated in section “Annex”. Disconnect the system from its power supply. After 5 sec. connect power and restart system.

System Malfunctions – continued –

System Malfunction 5

LED “Power” flashes slowly.

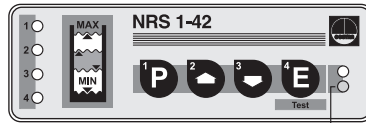

LED flashes slowly

Fault: The power supply unit (PSU) is overloaded. The power supply unit may be misused for other components.

Remedy: Check load of power supply unit. Be sure to use the PSU only for the voltage supply of network components.

Disconnect the system from its power supply. After 5 sec. connect power and restart system.

Fault: Power supply unit fails to function.

Remedy: Replace PSU.

Malfunctions



Danger

The terminal strip of the NRS 1-42 is live during operation.
This presents the danger of electric shock.
Cut off power supply before mounting or removing the equipment.

Fault finding list for troubleshooting

Device fails to work – indication of malfunction

- Fault:** In spite of correct wiring and commissioning of the equipment an interference signal is indicated.
- Remedy:** The interference signal is caused by H. F. interferences coming from the installation. For interference suppression of the voltage supply we supply ferrite rings, stock code 147253. The 230 V supply lines should be looped through the ferrite ring five to ten times. If several controllers are used in the system, they can be fed from the interference suppressed supply lines. For the interference suppression of the bus line we supply hinged-shell ferrite rings, stock code 147254. The hinged-shell ferrite rings are clamped onto the bus line close to the terminal strip of the controller.

Device fails to work – no function

- Fault:** LED “Power” does not light up.
- Remedy:** Turn on the power. Connect the equipment in accordance with the wiring diagram.

Switchpoints reached / level below switchpoints – no function

- Fault:** The electric conductivity is too low.
- Remedy:** Set sensitivity to $\geq 0.5 \mu\text{S/cm}$.

- Fault:** The electrode body does not have earth connection to the vessel.
- Remedy:** Clean seating surfaces and insert metal joint ring (of stainless steel 1.4301) D 33 x 39 to DIN 7603.
Do **not** insulate the level electrode with hemp or PTFE tape!

- Fault:** The vent hole in the protection tube does not exist, is obstructed or flooded.
- Remedy:** Check protection tube and, if necessary, provide vent hole.

- Fault:** The isolating valves of the external measuring pot (optional item) are closed.
- Remedy:** Open isolating valves.

Malfunctions – continued –

Fault finding list for troubleshooting – continued –

Switchpoints reached / level below switchpoints – incorrect function

Fault: The switching function has not been correctly allocated.
Electrode rods have been cut to the wrong size.

Remedy: Identify electrode supply wires and reconnect the circuit board in the terminal box accordingly.

If faults occur that are not listed above or cannot be corrected, please contact our service centre or authorized agency in your country.

Annex



Danger

The terminal strip of the NRS 1-42 is live during operation.
This presents the danger of electric shock.
Cut off power supply before mounting or removing the equipment.

Factory set default values of node IDs

Switching controller

NRS 1-40 ID:001
NRS 1-41 ID:006
NRS 1-42 ID:020
NRS 2-40 ID:039
NRR 2-40 ID:040
LRR 1-40 ID:050

Level electrode

NRG 16-40 ID:002
NRG 16-40 ID:003
NRG 16-41 ID:007
NRG 16-42 ID:021
NRG 26-40 ID:041
LRG 16-40 ID:051

The individual node IDs must be manually adjusted on the equipment.
Please observe the installation instructions of the device in question.

Assigning / changing node ID

If several systems of the same kind are to communicate in one CAN bus network, be sure to assign one node ID for each individual system component (e. g. controller).

Detach terminal strips **A** in order to change the code switch **B** settings.



Attention

- Do not assign the same node ID twice within the CAN bus network.

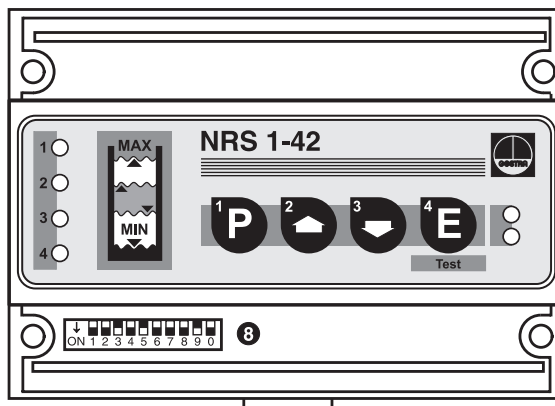

Fig. 7



		Node ID	20
S1	OFF	1	
S2	OFF	2	
S3	ON	4	
S4	OFF	8	
S5	ON	16	
S6	OFF	32	
S7	OFF	64	

Fig. 8 (Factory setting)



		Node ID	70
S1	OFF	1	
S2	ON	2	
S3	ON	4	
S4	OFF	8	
S5	OFF	16	
S6	OFF	32	
S7	ON	64	

Fig. 9 (Example)

S8	S9	S0	Baud rate	Cable length
OFF	ON	OFF	250 kBit/s	125 m
ON	ON	OFF	125 kBit/s	250 m
OFF	OFF	ON	100 kBit/s	335 m
ON	OFF	ON	50 kBit/s	500 m
OFF	ON	ON	20 kBit/s	1000 m
ON	ON	ON	50 kBit/s	1000 m

Fig. 10 (Factory setting: 250 kBits/s)

Note on the Declaration of Conformity / Declaration by the Manufacturer CE

For details on the conformity assessment according to the European Directives see our Declaration of Conformity or our Declaration of Manufacturer.

The current Declaration of Conformity / Declaration of Manufacturer are available in the Internet under www.gestra.de/document or can be requested from us.

Key

- A** Terminal strips
- C** Supporting rail 35 x 15 to DIN EN 50022

Example of Installation

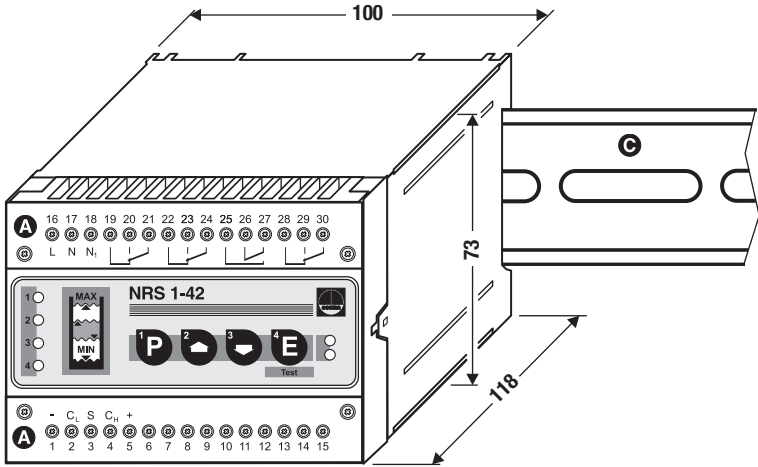

Fig. 11

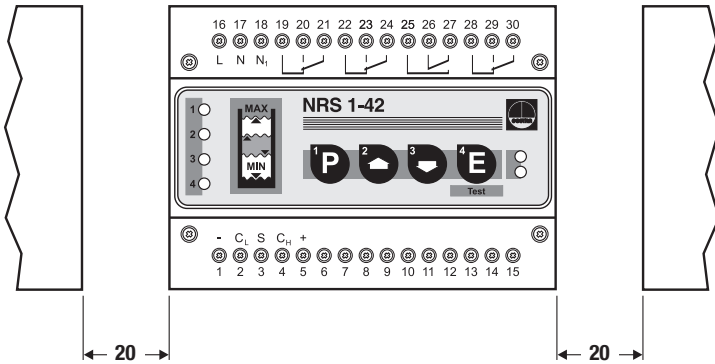

Fig. 12



Agencies all over the world: www.gestra.de

GESTRA AG

Münchener Straße 77

28215 Bremen

Germany

Telefon +49 421 3503-0

Telefax +49 421 3503-393

E-mail info@de.gestra.com

Web www.gestra.de